

# SAP

## SALES ORDER – SHIP CONFIRMATION

---

This application confirms a sales order has been delivered/shipped to a customer and removes the materials being shipped from inventory.

2021

RFgen provides its customers SAP-validated, ready-to-use suites of Open Source applications that can be used to create new apps or to modify existing apps.

This document describes the business workflow and technical information used in this application.

## SAP: Sales Order (SO) – Ship Confirmation

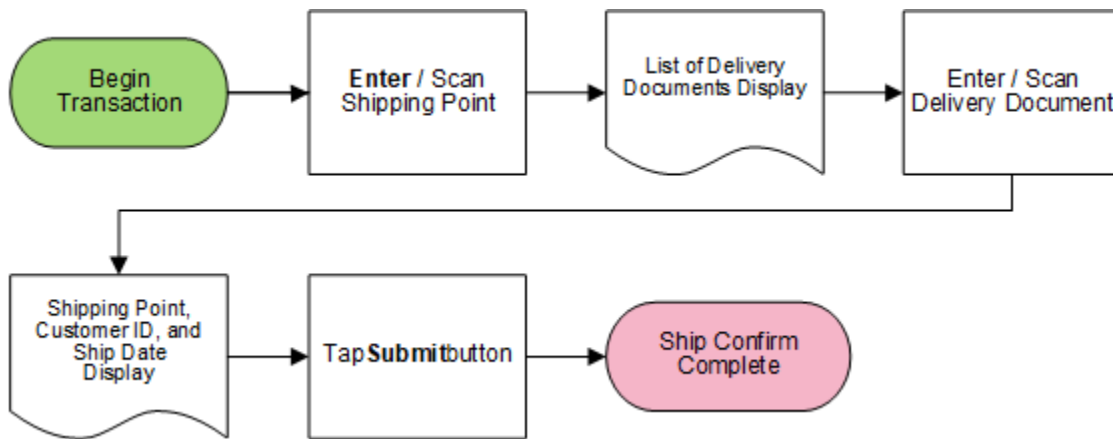

## FSOSC0200 – Ship Confirmation

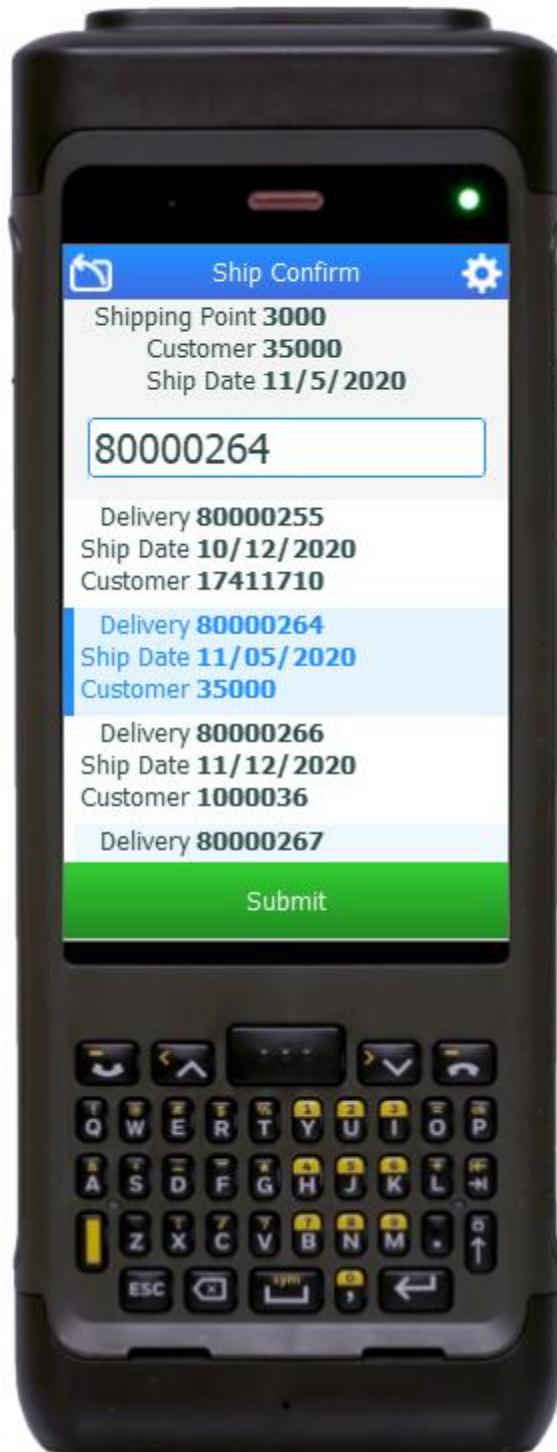

This application confirms a sales order has been delivered/shipped to a customer and removes the materials being shipped from inventory..

### Description of Workflow

First the user scans, enters, or searches for a Shipping Point.

A list of delivery documents that are ready for shipment displays.

The user scans, enters, or selects a delivery document that documents the materials to be shipped and removed from inventory.

The **Submit** button displays, and the user taps the Submit button. This posts the shipment confirmation of the delivery to SAP and resets the application.

The arrow in the upper left corner removes the current entry and moves the cursor back to the previous prompt until the user reaches the menu.

## Technical Information

This lists the tables used for validations, searches and defaults by prompt if applicable.

<b>Prompt</b>	<b>Table</b>	<b>Description</b>
Shipping Point	TVST	Shipping Point Master
Delivery	LIKPUK view	Delivery Details
App Update	SD_DELIVERY_UPDATE_PICKING_1	Delivery Ship Update

